



KRISHITEK

INDUSTRIES PVT.LTD.

POWER REAPER

Model: REAPTEK KI120



USER MANUAL







❖ **BEFORE USE YOU MUST READ THIS MANUAL COMPLETELY – RETAIN FOR FUTURE US**

⚠ DANGER!



BREATHING IN CARBON MONOXIDE FUMES CAN KILL YOU!
To help protect against CO poisoning install a Carbon Monoxide detector.







NEVER use Petrol/Diesel powered equipment inside, especially a home, garage, tent, camper-van, caravan, motorhome or boat.

EVEN if doors, windows, vents and hatches are open. Only use **OUTDOORS** and as far away from doors, windows, vents and open hatches as possible to prevent inhaling fumes.

READING MANUAL BEFORE USE WILL HELP AVOID OTHER MACHINE HAZARDS.



DANGER

Petrol is a dangerous substance; it is a highly flammable liquid and can give off vapour which can easily be set on fire, and when not handled safely has the potential to cause a serious fire and/or explosion.

This means there is always a risk of a fire and/or an explosion if there is a source of ignition nearby, for example a naked flame, an electrical spark or similar. Because of these risks storing petrol safely is covered by legislation; and this applies to you if you store petrol.

All containers must be clearly and correctly labelled so people are aware of their contents and hazards. All containers must be marked or labelled in a legible and indelible form with:

- the words 'PETROL' and 'HIGHLY FLAMMABLE';
- an appropriate hazard warning sign, for example:
- plastic containers up to 10 litres.
- metal containers up to 20 litres.



Suitable storage place is defined and covered by Petroleum (Consolidation) Regulations 2014

NO MORE than 30 litres of petrol can be stored without licence kept in no more than two suitable portable containers in any motor vehicle, motor boat, hovercraft, aircraft, home, garage, tent, caravan and boat.

Common storage requirements are;

Petrol is NOT to be stored in living accommodation;

Petrol is not dispensed* at the storage place;

If the storage place is not in the open air, it has a direct exit to the open air and is ventilated to it.

All reasonable precautions are taken in the storage place to prevent any sources of ignition or heat that would be liable to ignite petrol or its vapour;

Petrol is not used in the storage place other than:

- in the fuel tank of any internal combustion engine;
- in quantities (not exceeding 150 millilitres at any one time), for cleaning or as a solvent for repair purposes.

* Dispensing means manual or electrical pumping of petrol from a storage tank.

❖ BEFORE STARTING MACHINE

⚠ CAUTION ⚠ WARNING

- The Engine is shipped from the factory without oil. Fill with **SAE 15W/40, 10W30, Grade SJ lubricating oil for Petrol engines**, Check oil level before starting engine. If you start engine without oil, The engine will be damaged beyond repair and will not be covered in warranty.
- Check the engine oil level with the engine stopped and the machine in a level position.
- Remove oil filler Cap/Dipstick and wipe it clean.
- Insert the oil filler Cap/Dipstick into the oil filler neck as shown, but do not screw it in, then remove it to check the oil level.
- If the oil level is near or below the lower limit mark on the dipstick, fill with recommended oil to the upper limit, **DO NOT** overfill.
- Re-install the oil filler Cap/Dipstick.

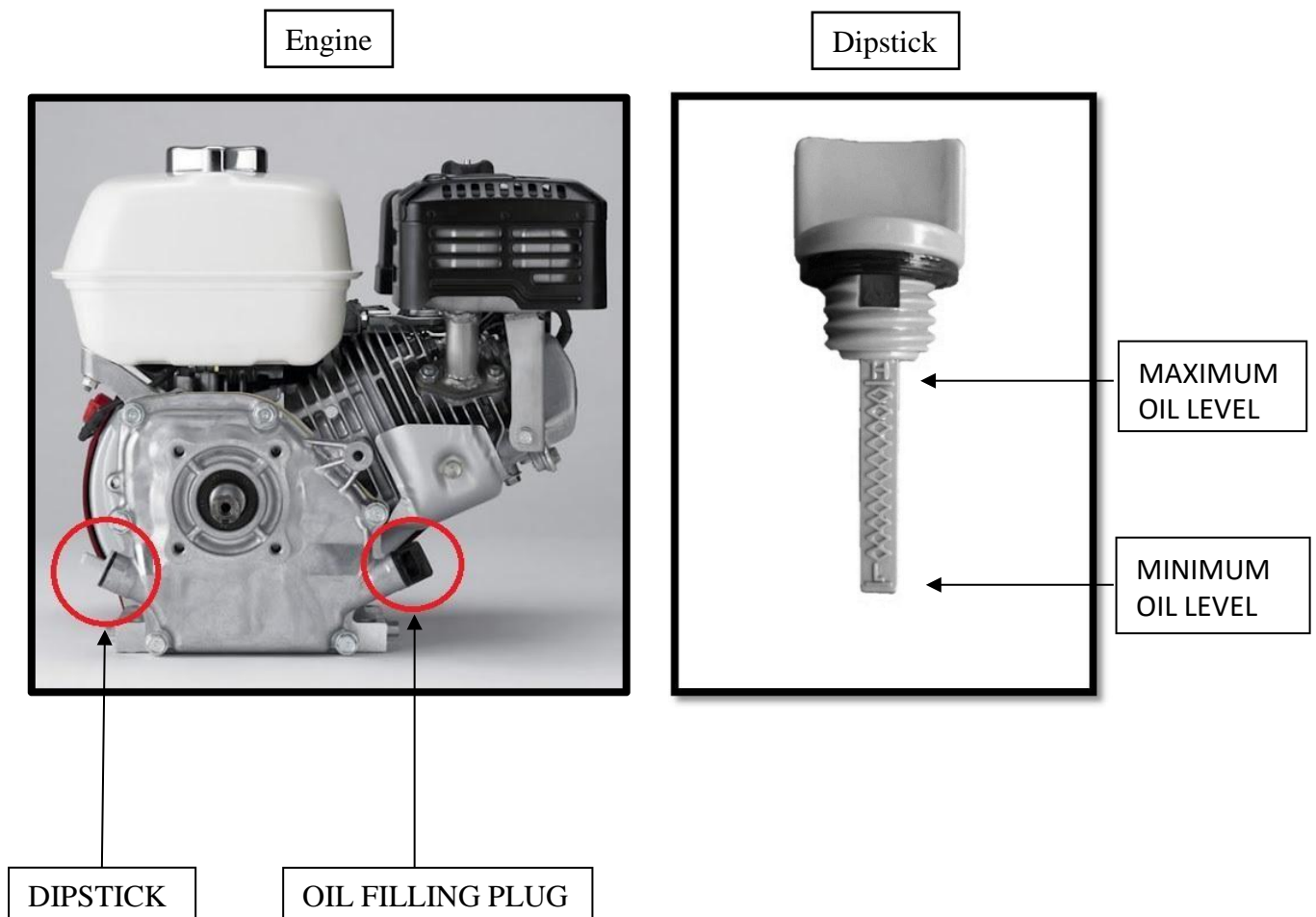

❖ **BEFORE STARTING MACHINE** ⚠ **CAUTION** ⚠ **WARNING**

- The Gearbox is shipped from the factory without oil. Fill with **SAE 90 or higher grade lubricating oil for gearboxes**, Check oil before starting engine. If you start gearbox without oil, The Gearbox will be damaged beyond repair and will not be covered in warranty.
- Check the gearbox oil with the engine stopped and the machine in a level position.

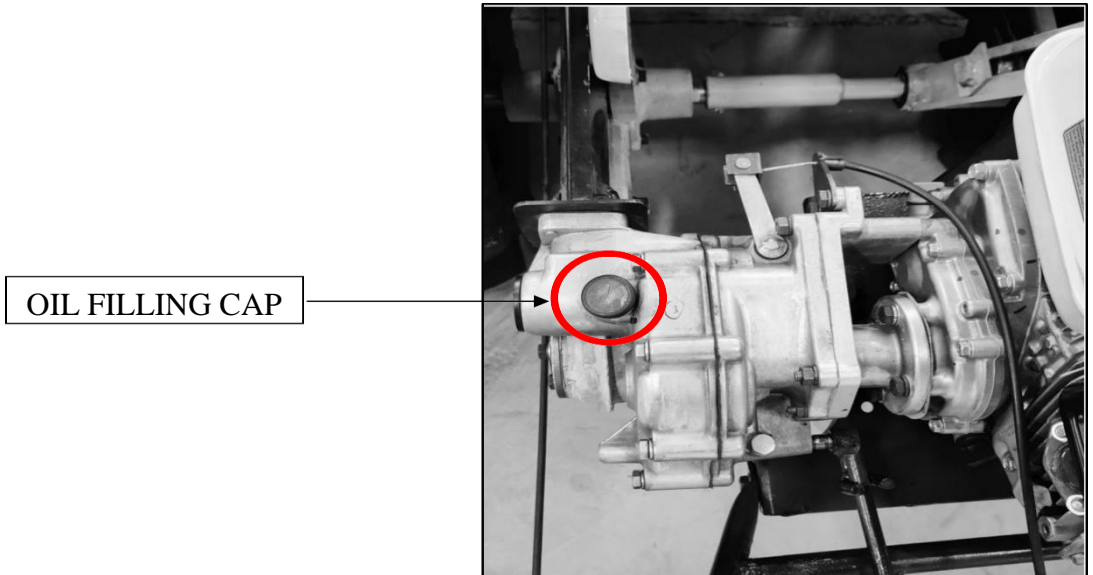

❖ **Grease**

Grease is a lubricant composed of an oil thickened with a soap or other thickener to a solid or Semi fluid consistency and is widely used for lubrication of rolling-element bearings, gears, and many others parts . You have to fill the grease on your own side in the space given below points.

➤ **Grease point**

1. Bearing Housing



2. Wheel chain

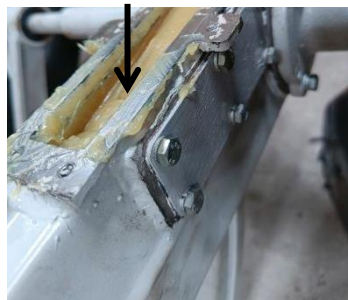

3. Bevel gearbox



CONTENTS







Section Description	Page
CARBON MONOXIDE POISONING – FUEL WARNING	2
OIL WARNING	3-4
1. SAFETY	6 - 9
2. MACHINE PARTS	11
3. ASSEMBLY PROCEDURE	12
4. OPERATING PROCEDURES	13 - 17
5. SOP (OPERATING PROCEDURE FOR REAPER)	18
6. CONTACT DETAILS	20

1. SAFETY.

- The Operator of the machine is responsible for and has a duty of taking care in making sure that the machine is operated safely and in accordance with the instructions in this user manual. Please note the following safety points
- The machine should never be left in a condition which would allow an untrained or unauthorised person/s to operate this machine.
- All due care and diligence should be taken by the operator for the safety of and with regard to those around whilst using the machine
- Some or all of the following PPE, Warning Signs and symbols may appear throughout this manual and you must adhere to their warning/s. Failure to do so may result in personal injury.

Personal Protective Clothing (PPE)



 DANGER	 WARNING	 CAUTION	 NOTE	 
Non-observance will result in the risk of serious injury or death to Oneself or others.	Non- observance will result in the risk of injury to Oneself or others.	Indicates a hazard which, if not avoided, might result in minor or Moderate injury.	Note or Important These give details or further information on what has already been said, and aim to prevent damage to the machine or cause Other damage.	Read Manual



❖ **Carbon Monoxide.**



- Carbon monoxide is a colourless and odourless gas, inhaling this gas can cause death as well as serious long term health problems such as brain damage.
- The symptoms of carbon monoxide poisoning can include the following; Headaches, dizziness, Nausea, Breathlessness, Collapsing or loss of consciousness.
- Carbon monoxide symptoms are similar to flu, food poisoning, viral infections and simply tiredness. That's why it's quite common for people to mistake this very dangerous poisoning for something else.
- To avoid carbon monoxide poisoning DO NOT Use Petrol/Diesel powered equipment inside a home or garage even if doors and windows are open.
- If you think you have or someone around you has been affected by carbon monoxide poisoning;
- Get fresh air immediately.
- Open doors and windows, turn off machine and leave the affected area.
- See your doctor immediately or go to hospital - let them know that you suspect carbon monoxide poisoning.
- Only use Petrol/Diesel powered equipment outside in a well-ventilated area.

❖ **General fuel safety.**



 **CAUTION**

All fuels are Flammable.

- Fuel Safety additional information can be obtained from the Health and Safety Executive.
- Keep away from all ignition sources i.e. Heaters, Lamps, sparks from Grinding or welding.
- Hot work on tanks that have contained fuel is extremely dangerous and should not be carried out.
- Keep work area clean and tidy.
- Clean up all spills promptly using correct methods i.e. absorbent granules and a lidded bin.
- Dispose of waste fuels correctly.

❖ **Petrol safety.**



- Always fuel and defuel in well-ventilated area.
- Always wear correct, suitable and fit for purpose Personal Protective Equipment (PPE), suggested items are as follows, but are not limited too.

- Hand protection.









- Protective clothing.



- When defueling always use a propriety fuel retriever.
- Always carry fuel in the correct and clearly marked container.

❖ **Machine safety.**

 DANGER	<p>Continual and regular users should monitor closely the condition of their hands with regard to White finger disease or carpal tunnel syndrome. If you think you have been affected seek medical advice immediately.</p>
 WARNING	<p>DO NOT modify the unit in any way. Only use the machine for the job for which it is intended. Always remove HT lead from spark plug when checking machine or changing parts.</p>
 CAUTION	<p>DO NOT operate the equipment when barefoot or wearing open sandals. Recommended PPE but not limited too.</p> <div style="display: flex; justify-content: space-around; align-items: center;">     </div>

- Inspect machine before each use, and replace any damaged parts before operation. Check for fuel leaks and make sure all fasteners are secure and in place.
- Replace parts that are cracked, chipped or damaged in any way before using the machine.
- Stop the engine before working on machine for maintenance.
- Never put feet or hands near the machine blades when running. Before Harvesting, remove all large object, which may cause injury or damage.
- Keep children, people and pets at a safe distance when the weeder is in use.
- Do not operate this rotary machine after drinking, taking medication or drugs that can impair your judgment.
- Use only recommended accessories and parts, approved by the manufacturer. Non approved parts may cause damage to the machine or harm to the user, and will also void your machine's warranty.
- Under no circumstances should you ever take the product apart or alter it in any way even if the item is faulty. You may damage or cause further harm by taking the product apart and you will void your warranty in doing so.
- This machine is designed exclusively for Harvesting in a private domestic setting. Using it for any other purpose other than those intended qualify as improper use. The operator is solely responsible for assuming all risks.
- You should prevent the equipment from coming into contact with buried electrical cables, earthing devices, such as pipe-lines. Making contact with these may cause electric shock and/or damage to your machine.
- The machine will work better when operated within its specified performance range.
- If blade is blunt, Need to sharpened or replace it. Blunt blades will not cut the crop efficiently so check blade carefully before each use.
- Before maintaining the equipment, replacing the parts, cut off the power supply.
- Before cleaning, maintaining or checking the equipment, cut off the power supply of the machine to ensure that all moving parts have stopped.
- The machine should be maintained by the professional maintenance personnel. All Maintenance or service by non-professionals may result in users' injury or equipment Damage.
- If the equipment is running abnormally, please stop the engine, and carefully check all the parts to see if any part is damaged, repair it before re-starting and using the equipment.

- If the machine comes into contact with big blocks, root or vine, The equipment will spring upwards Or leap forwards. Stop machine and remove HT lead before removing any blockages
- Avoid pulling the machine whilst the engine is running.
- Keep and read the instructions often.
- Use them to show others to operate this machine safely.
- When the equipment is not being used, please remove the spark plug HT lead to avoid accidental starting.
- You must only work in good natural light.
- Cutoff the Power supply of the cutting platform while cleaning crops. It is strickly forbidden to stretch the hand towards the cutter.
- When Turning or moving the machine in reverse direction, reduce the accelerator and stop cutting.
- Do Harvesting or Moving the machine in reverse direction, Reduce the accelerator and stop cutting.
- Do Harvesting only when the machine runs stably. Ensure the machine is in good Working condition, With the handles flexible and reliable, and the transmission parts running normally.
- For harvesting the loading crop, Converse harvesting gives better efficiency.
- Check the bolts of the gear box, gear case and the bearing base regularly.

2. MACHINE MAIN PARTS

❖ Parts.

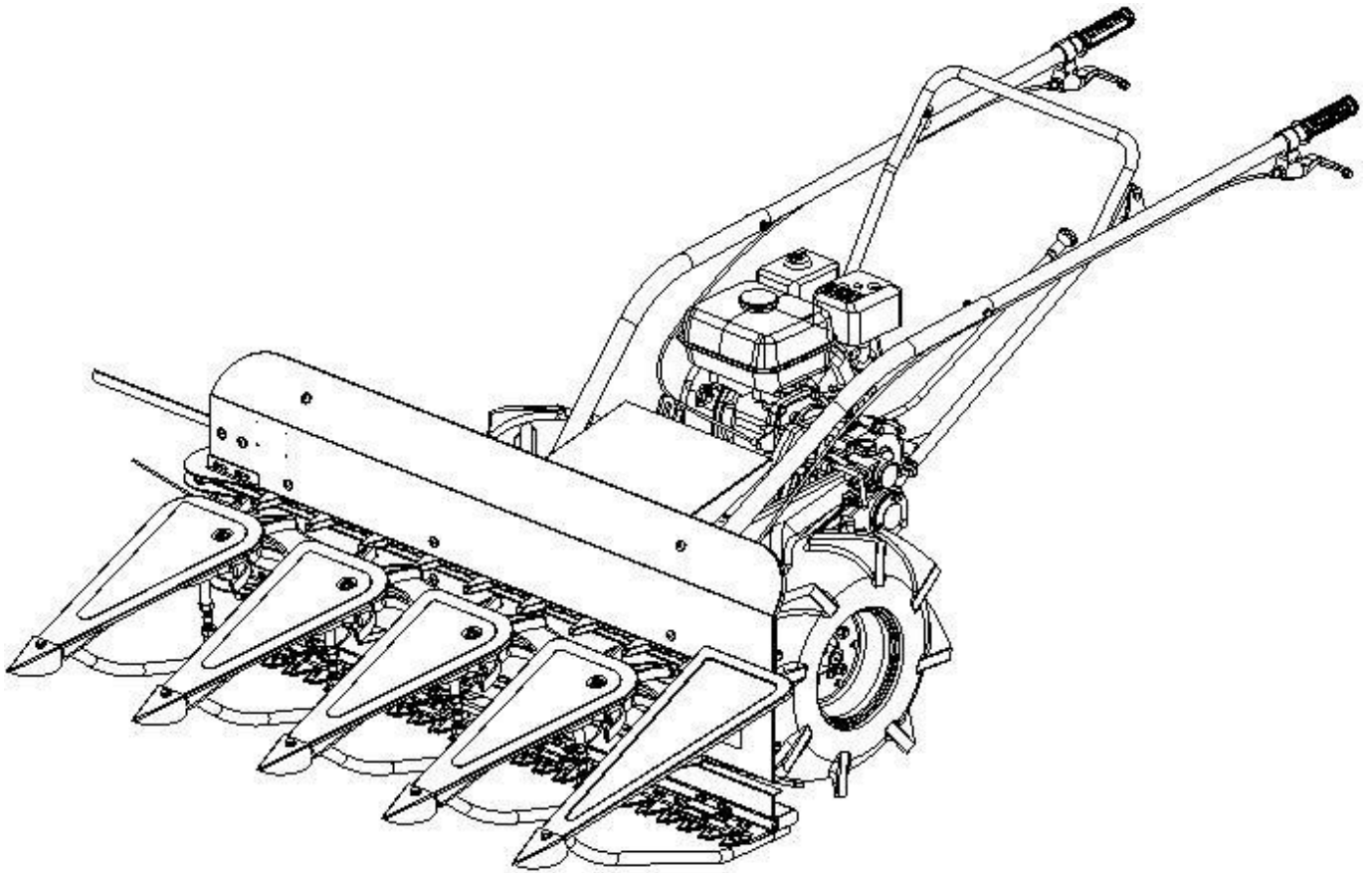

Guide Leaf	Conveyer Chain
Cutter Bar	Main Gearbox Assembly
Petrol Engine	Gearbox for Cutter
Wheels	Star Wheels
Cut sets aside clutch	Main Clutch
Steering handle	Crop separator

3. ASSEMBLY PROCEDURE

❖ Remove machine from packaging.

- Dispose packaging in accordance with local recycling regulations. (Check that the machine is undamaged and in working order before disposing of packaging – We recommend that you retain packaging to use should you wish to return the machine for servicing).

❖ Wheel assembly.

- Assemble wheel support to wheel base with bolts and nuts and inflate tyre with 1.5 bar air pressure, notice valve must be directed inwards.
- Align the hole of wheel axles B with the hole of output shaft A and fix them by hex bolt M8 X 1.25 X 60 and hex flange nut M8 x 1.25 as shown in picture.

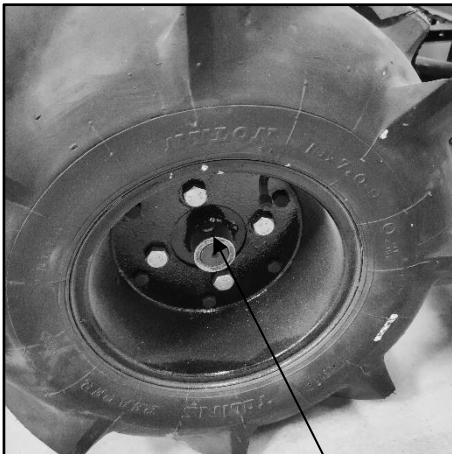

Hex Bolt

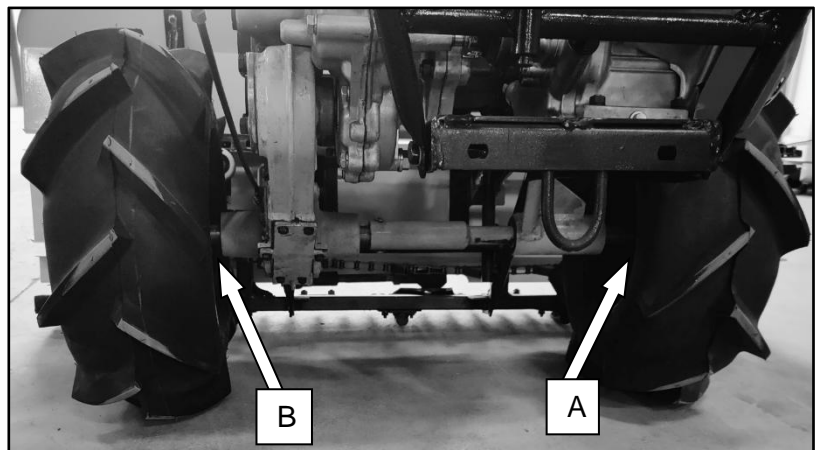

❖ Guide Leaf Assembly

- Five Guide Leaf Assemblies Provide along With Machine Separately.
- Assemble Leaf assembly to cutter Bar Assembly With help of two M8 x 1.25 x 25 Pan Head Screws As show in Images.



Leaf Assembly



Before Leaf Assembly

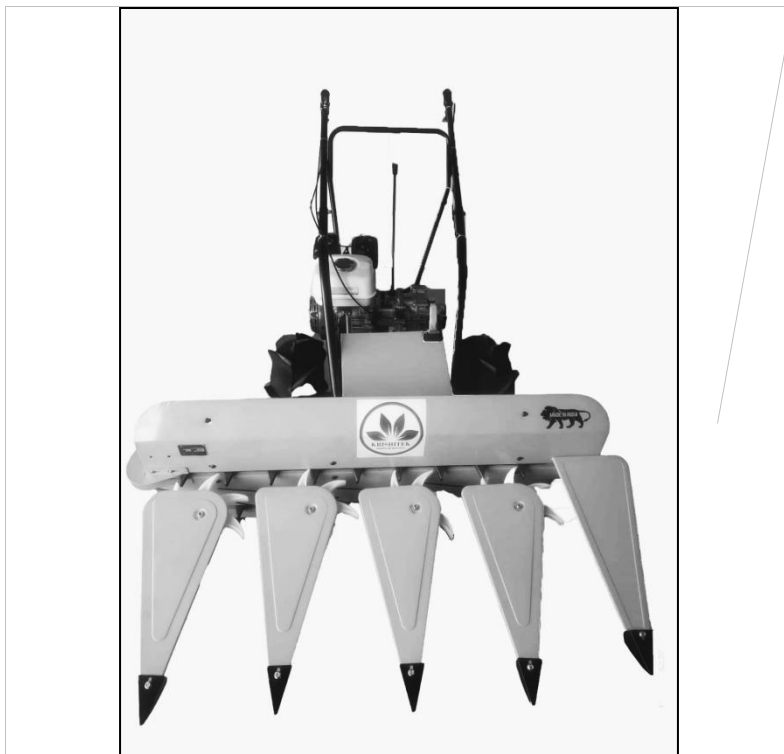

After Leaf Assembly

4. OPERATING PROCEDURES

CAUTION

Always stop the engine before adding fuel, water or making any adjustments to the machine.

Never put feet or hands near the weeder blade especially when machine is running. Before Harvesting, remove all foreign objects from the work area, which may cause injury or damage.

Always keep children, people and pets at a safe distance when the weeder is in use. Always wear correct PPE when using this machine.

Recommended PPE but not limited too.



❖ Filling with oil.

- The machine is supplied with no oil.
- Undo and remove filler cap and dipstick (Page 3 & 4).
- Carefully fill with oil approximately 0.6 L in engine & 1.5 L in gearbox, taking care not to spill. Clean up all oil fuel spills before use.
- Replace filler cap and tighten.

❖ Filling with fuel.

- The machine is supplied with no fuel before starting fill with fresh unleaded petrol.
- Pour in fuel (approx. 1 litre). Avoid spillages and clean up all spills straight away.
- Check seal inside the petrol cap for damage and replace if needed.
- Replace cap and screw on firmly by hand.

❖ Starting & stopping the machine.

➤ Preparation before starting.

- Before starting the engine, check that all components are in correct position and secured correctly.
- Check the oil level as in Oil warning page 3 & 4
- Oil type-with SAE 15W/40, 10W30, Grade SJ lubricating oil for Petrol engines.
- Check the machine has fuel, use fresh unleaded petrol.

➤ **Starting the engine.**

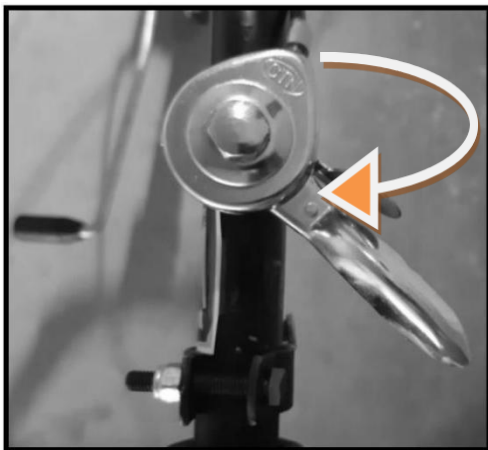

Pull



On-Off Switch

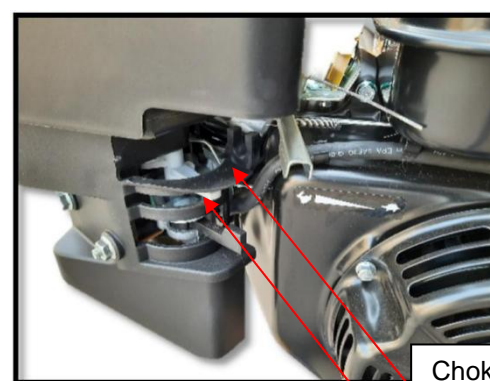

Choke Valve

Fuel Supply on/off valve

- Push the accelerator lever slightly.
- If machine does not start then push the accelerator lever once fully.
- Firstly move fuel supply lever at on position.
- Then switch on the engine as shown in picture by regulating knob.
- Pull the recoil starter gently, then pull sharply, do not let go of recoil starter handle, release slowly and repeat until engine starts.
- Once engine is running, adjust throttle to desired speed.
- If in case engine will not start by above procedure use choke valve & once engine is running move valve to off position.

➤ **Stopping the engine.**

- To stop the engine move regulating knob to off position as shown in the picture.

❖ **Accelerator lever**

- Speed of machine can maintain with the help of accelerator lever.
- To increase the speed of machine, push lever in clockwise direction as shown in picture.
- To decrease the speed of machine, push lever in anticlockwise direction.

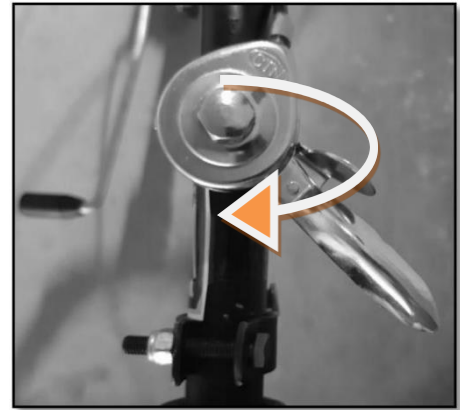

❖ **Clutch levers**

- Before operating the clutch, reduce the speed of the engine.
- The clutch connects/dis-connects the engine to the Wheels.
- When the clutch is released the wheels start to turn.
- When the Cutter-clutch is closed the cutter blades will come to a stop. The engine Continues to run.
- Clutch lever must be pressed before Following operation:

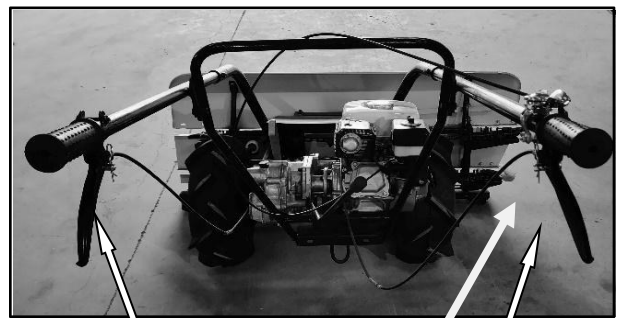

Cutter Clutch lever

Main Clutch lever

1. Before stopping the machine.
2. Before shifting of gear 1st or 2nd.

(Note: if any of the above operations is done without the use of a clutch lever can damage machine parts and will not cover under warranty.)

❖ Clutch Lever adjustment

- Clutch lever can be adjusted with the help of screw as shown in the picture.
- If the machine or PTO shaft will not stop after pressing clutch lever move screw upward with the help of spanner to adjust lever as shown In the picture.

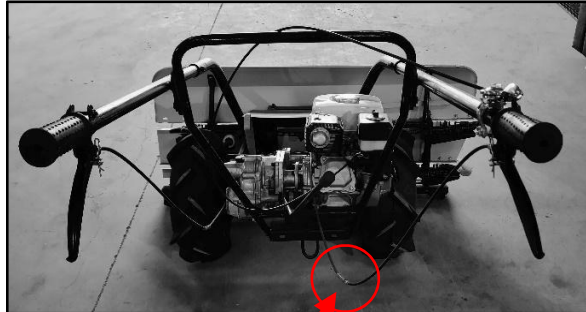

Adjustment

❖ Gear shift.

- Gear can shift with the help of the gear shifter.
- 1st gear engagement can be achieved by pulling the gear shifter in backward direction from neutral position.
- 2nd gear engagement can be achieved by pushing the gear shifter in a forward direction from neutral position as shown in the picture.

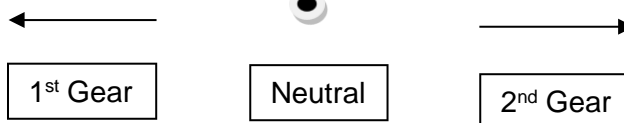
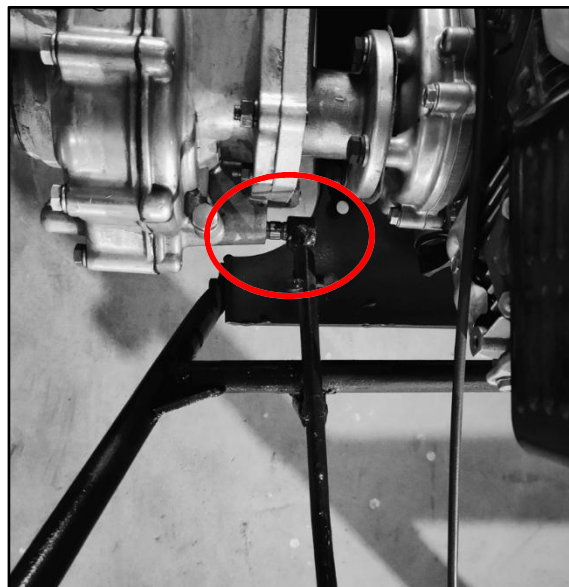

❖ Working Of Conveyor Chain

- For the proper tension rate of the upper and lower conveying chain, It should make the crop conveying smoothly. It is available by loosening the adjustable nut of the passive sprocket to move left and right, so as to change the tension of the conveying chain.
- Check the tines and riveting of the upper and lower conveying chains, and repair them accordingly if there is any loosening or is lost.
- Check the correspondence of the tines on the upper and lower conveying chain. Please adjust if it is not correspondent.

❖ Working Of Cutter

- The Working faces of the moving and fixed knives should be on same plane, with the difference not more than 3mm. The space in the front should be not more than 0.4 mm, and the space on the back should not more than 1.5mm. The space between the moving knife, the rod and the friction plate of the knife pressure should be not more than 0.5mm. It is necessary to adjust the space, keep the knife rod vertical, Adjust the knife pressure by increasing or decreasing the spacer, or to replace the knife, so as to keep the above status.
- The beginning and ending lines of the centre route of all moving knives should be coincide with the central lines of the neighboring fixed knives, with the difference not more than 5mm. if it does not coincide, adjust the length of connecting rod accordingly.
- Check the riveting of the moving and fixed knives if there are more than 1/3 knives lost or damaged. It would be necessary to replace the knives. It is also require to check bolt of the knife pressure to avoid any loosening.

❖ Normal operating angle.

- The Angle Between the placing and the moving direction could be $90^{\circ} \pm 20^{\circ}$. It could be adjusted according to the actual status by adjusting the bending degree of the crop leading plate.
- The required final depth of weeding may only be reached by increasing depth over several passes.
- During the first pass, the you should keep the depth shallow.
- If the machine bounces or shakes, you should adjust the speed to reduce bouncing and shaking.
- If the machine does not move forwards, but only digs on the spot, re-balance the machine to help it to move along.
- Avoid weeding if the soil is very hard, irrigate it a few days before the cultivation.
- Do not work on wet ground. If there has been a heavy rain on the working site, wait one to two days to make the soil dry.

5. SOP OF POWER REAPER (OPERATING PROCEDURE FOR REAPER)

- First of all you have to check engine oil and gear oil level.
- You have to Fill up petrol and take out air from the carburetor, Do this every time the tank is full.
- After pulling the rope of the engine, once you have to check that nothing is being touched by anyone.
- The gears must be in neutral position before starting the machine.
- On-Off switch should be on, Petrol supply knob should be in line with arrow, choke should be off.
- Start the engine by pulling the rope.
- Shift the gear after pressing the clutch.
- Use the accelerator lever to increase or decrease the speed.

❖ पावर रीपर की एसओपी (रीपर के लिए संचालन प्रक्रिया)

- सब से पहले आपको इंजन ऑयल और गियर ऑयल लेवल चेक करना हैं !
- आपको पेट्रोल डालना हैं और कार्बुरेटर में से हवा निकालनी हैं यह हर बार करना हैं जब टैंक भरते हैं !
- इंजन की रस्सी खींच के एक बार चेक कर लेना हैं की कोई चीज किसी को टच तो नहीं हो रही !
- मशीन शुरू करने से पहले गियर न्यूट्रल पोजिशन में होना जरूरी हैं !
- On-Off स्विच On होनी चाहिए, पेट्रोल सप्लाई नॉब ऐरो की लाइन में होना चाहिए , चॉक बंद होना चाहिए !
- रस्सी खींच के इंजन को शुरू करो !
- क्लच दबाने के बाद गियर को शिफ्ट करे !
- स्पीड कम ज्यादा करने के लिए एक्सीलरेटर लीवर का उपयोग करे !

Machine bolt's Torque Chart

Torque Chart (Nm)	
Bolt Thread Diameter	Grade 8.8
M4	2.5
M5	4.8
M6	9.5
M8	23
M10	44
M12	81
M16	160
M18	220

PRE DELIVERY INSPECTION & CHECK LIST

DISPATCH DATE	PRODUCT	SR.NO	FARMER NAME	LOCATION	MOBILE NO.

PARAMETERS

SR.NO	CHECK LIST	YES	NO	REMARK
1	ENGINE OIL			
2	GEAR OIL			
3	AIR CLEANER OIL			
4	GEAR SHIFTING LEVER			
5	CLUTCH CABLES			
6	ACCELERATOR CABLE			
7	ANY DAMAGE IN MACHINE			
8	PAINT QUALITY			
9	TOOL KIT AND MANUAL BOOK			
10	LEAF ASSEMBLY			
11	GREASE (CHAIN COVER ,SMALL GEARBOX,BEARING HOUSING)			
12	NUT BOLTS			



Krishitek Industries Pvt.Ltd.

Plot No.40, Prime Industrial Park, Santej, Ta-Kalol, Di-Gandhinagar
Gujarat, India, Pin-382721
Contact No.:- 09925012936, Email :- info@krishitek.com
www.krishitek.com